

## Getting more out of your WFS-43

See the full manual for information about features available:

- Use the Home Net option. That way you can leave you phone or tablet connected to your home network. When you power up your WFS-43, your phone or tablet will connect much more quickly.
- Explore the WFS-43 web pages to see the features available.
- Use the WFD-60 Gateway to control switches using WiThrottle, or Engine Driver apps on phones, while driving trains.
- Build Schematic Control Panels on your WFD-60 to control turnouts and other layout features..
- Access the WFS-43 Manual at <http://www.wifitrax.com/manuals/WFS-42-43/WFS-42-43-Manual.pdf>
- Access the WFD-60 Manual at <http://www.wifitrax.com/manuals/WFD-60/WFD-60-Manual.pdf>

**This product is not a toy. Keep away from children. It is not suitable for use by persons under 14 years of age.**

**Warning: This product contains chemicals known to the state of California to cause cancer, birth defects or other reproductive harm.**

WifiTrax products are made in Australia using globally-sourced components and services. Check our website for warranty information.

# WifiTrax

[www.wifitrax.com](http://www.wifitrax.com)



## WFS-43 Getting Started Guide

This document is online at <http://www.wifitrax.com/appNotes/quickStart/WFS-43-Quick-Start.pdf>. Please consult the full WFS-43 manual for much more detail at <http://www.wifitrax.com/manuals/WFS-42-43/WFS-42-43-Manual.pdf>

Package Contents: WFS-43 Module in Static Shielding Bag, mounting Kit

## WFS-43 4-Way Wi-Fi/DCC Stall-Motor Only Switch Machine Controller

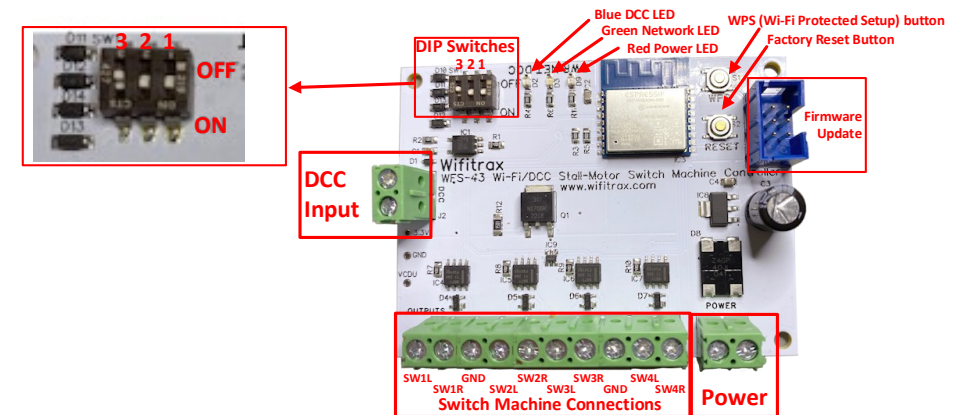

Figure 1 WFS-43 Connections

The WFS-43 provides control for up to 4 switch machines, of stall motor type. Turnouts can be operated through its DCC Input or by its web browser interface. With the addition of a Wifitrax WFD-60 Gateway, multiple WFS-43 devices, each with groups of four switches, can also be operated from phone apps, or using the WFD-60 lists and Schematic Control panels. The WFS-43 does not control twin-coil switch machines.

SW1	SW2	SW3	Output Voltage
OFF	OFF	OFF	Approx. (Power Voltage – 3V)
ON	OFF	OFF	Lower of 19V or (Power Voltage – 3V)
OFF	ON	OFF	10-11V
OFF	OFF	ON	7-8V

Table 1. Voltage DIP Switch Settings

Two LEDs indicate Power (red), and Network (green).

## Wiring for Stall-Motor Switch Machine Types

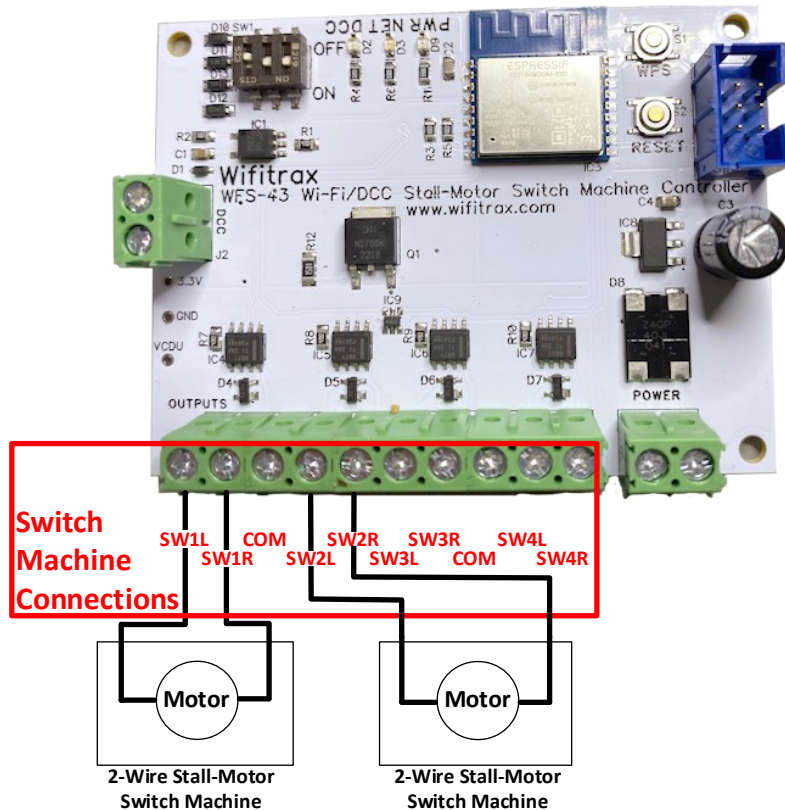

Figure 2. Connection Diagram for Stall-Motor Switch Machines

## Connecting the WFS-43 to your Home Network

Before your WFD-60 can find the new WFS-43 module, you will need to set the WFS-43 as a station on your home net. There are two ways of doing this. Wi-Fi Protected Setup (WPS) and manually.

You can use the WPS button only if your router has that capability. First press the WPS button on your router, then once it indicates WPS mode, usually by flashing an LED, press the WPS button on the WFS-43. After flashing a few times, the WFS-43 will connect to the router and the green LED will stay on continuously. You can now let your WFD-60 find the channels of your WFS-43 module.

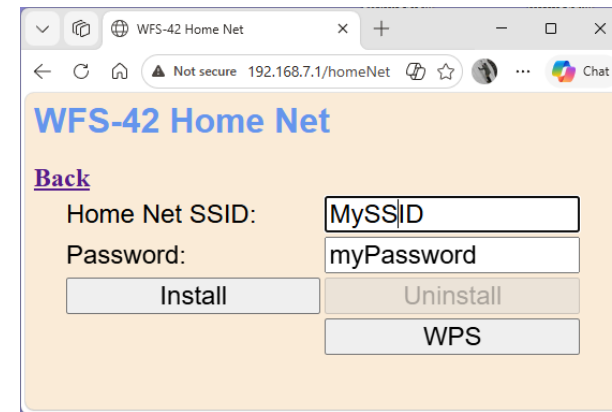

Figure 3 The WFS-43 Home Network Screen

If for some reason the WPS method does not work, use the Home Net screen in Figure 3, accessed from the main menu, to enter the SSID and Password.

## Direct-to-Module DCC Operation

The WFS-43 supports DCC being connected directly to the module. To control turnouts with DCC via the WFS-43, connect your DCC track power to the DCC Input shown in Figure 1.

You can use more than one WFS-43 on your layout and connect each one to the same DCC signal. However, each channel on your collection of WFS-43 Switch Machine Controllers must have a unique DCC Address. You can set this by accessing the WFS-43 Switch Machine Channels screen as in Figure 9 and clicking on the Name hyperlink to show the Switch Channel Edit screen as Figure 4.

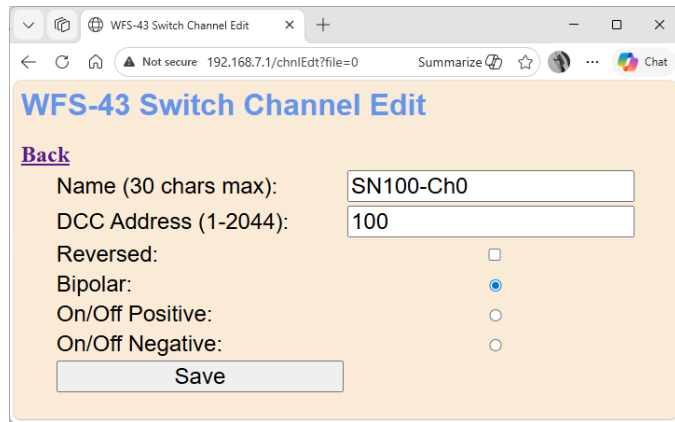

Figure 4 The Switch Machine Channel Edit Screen

On this screen you can change the Name and DCC Address as well as the Reversed flag. This causes the Closed/Thrown output voltage polarity to be reversed. The Name can have up to 30 characters but only the first 10 are recorded by the WFD-60, so it's best to name the channels 10-Digit unique names.

The Accessory Address can be 1 to 2044 and, as said earlier, each channel must have a unique DCC Address on your layout.

The other settings are not relevant to the WFS-43.

## Installation Instructions

- (1) Consider the various system-level options for turnout control described in this document and decide how your turnouts are ultimately to be controlled. First you will need to connect and get it working as a single unit as Figure 7.
- (2) Figure 1 shows the WFS-43 module with its connections and switches labelled. Configure the DIP Switches on your module to provide a suitable output voltage as in Table 1. Do not set the voltage too high for the switch machine in use. If in doubt start with the lowest voltage and increase until it works. The output voltage cannot be higher than about 3 volts less than the supply voltage.
- (3) The WFS-43 only controls Stall-motor Switch machines, so you must use that type. You can connect up to four switch machines as in Figure 2. Connect your WFS-43 to DC or DCC power, 12 – 18 Volts. About 15 V DC is usually ideal or about 14-15 V Peak-Peak DCC. It does not matter which way around you connect the power. Do not turn on the power until ready for testing. Mount your WFS-43 suitably so that it does not move around and possibly touch track voltage. If it does, it will likely be destroyed.

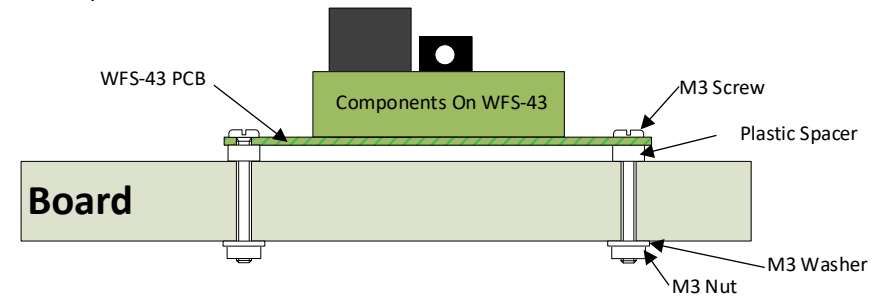

Figure 5 Mounting Suggestion

## Basic Testing of your WFS-43

Once you have installed your WFS-43, you can test and configure it using its web pages which are accessible from any browser on IOS, Android or Windows. You can do this before connecting it to your home network and integrating with a WFD-60.

### Connecting using an Apple IOS Phone or Tablet

- (1) Tap the Settings icon on your iPhone or iPad



- (2) Tap Wi-Fi on the left-hand menu. Under Other Networks on the right, the list should include one like wftrx\_WFS43\_1\_XXXXXXX\_7, where XXXXXXX is the serial number of your unit that appears on its label. Tap that Wi-Fi Network. **You must always connect to this Network to access the WFS-43 web pages** until you operate in home-net mode.

### Connecting using Android

- (1) Press the Home button and tap the Settings icon:



- (2) Tap Connections, then Wi-Fi and select the module's network as above.

### Connecting using Windows

- (3) On your Windows 10 desktop or laptop, click the networks icon in the system tray and select the network described above.

Figure 10 shows another alternative, operating all your turnouts using DCC provided by any Command Station/Booster. An NCE Power Cab is shown as an example with the Flat NCE Cable from the Power Cab connected to the Power Cab Panel (PCP) that comes with the Power Cab. The PCP receives power for the Power Cab using the NCE adapter (not shown) and the Track connections of the PCP are shown as the red and black wires on Figure 10 that are connected to your track to provide DCC power for the locos. However in the diagram, they are also connected to the DCC inputs of the WFD-60. When a DCC Accessory Control is sent from the Power Cab with a specific Accessory Address, the WFD-60 will identify a WFS-43 channel in its list corresponding to that Accessory Address and send a command via Wi-Fi to set the Switch Machine to the state specified by the Power Cab. Thus all of the WFS-43 controllers behave as though each had a DCC input.

Once the Power Cab (or other Command Station/Booster is connected, you can add to the versatility by connecting a WFD-30 or WFD-31 to its Cab Bus. Now you can control the DCC locos on your layout and the Turnouts from a phone or tablet running Engine Driver or WiThrottle, or indeed the TCS-UWT-100 or UWT-50.

To understand how to set all this up, consult the manual for the WFD-60, but to make the WFS-43 a station on your Home Net, you can use the WPS button or the Network Screen.

This means that rather than each acting as a direct Wi-Fi Access Point, they must all be stations under the router which will assign them unique IP Addresses. Figure 6 shows the WFD-60 communicating via Wi-Fi with a group of WFS-43. The physical wire connections to the stall-motor controllers are not shown. Once the WFD-60 is aware of all the Switch Machine Channels on your layout, they appear in a list on one of the WFD-60's own web pages and can be operated from buttons on that page.

With the WFD-60 you can also define a set of Panels. Each Panel can be edited to show a schematic diagram of all or part of your layout. Turnouts can be included in the diagram and associated with a switch machine channel on one of the WFS-43. When you have finished editing and open one of the Panels in Operational Mode, you can toggle the state of any turnout by clicking or tapping on that turnout in the panel's diagram. You can operate these panels from almost any up-to-date browser on a computer, or tablet running Windows 10/11, Android or Apple IOS.

Browser on Tablet/Computer on Home Net Connected to WFD-60

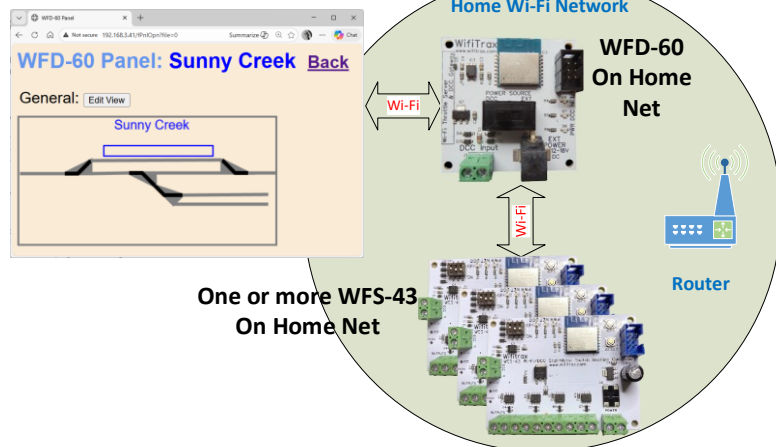

Figure 6. Controlling turnouts using Panels on a WFD-60 with all devices on home net

## Testing using the WFS-43 Web Pages

192.168.7.1/channels

Default IP Address  
192.168.7.1

Browser on device connected to WFS-43 Direct Access Point

WFS-43 Switch Machine Channels

Back

Channel	Name	DCC Address	State
0	<a href="#">SN100-Ch0</a>	100	Closed
1	<a href="#">SN100-Ch1</a>	101	Thrown
2	<a href="#">SN100-Ch2</a>	102	Closed
3	<a href="#">SN100-Ch3</a>	103	Closed

Save as Default

WFS-43

WFS-43 Direct Wi-Fi Network

Figure 7 Controlling the WFS-43 Channels via its web interface

Figure 7 shows how the web pages generated in the WFS-43 control its connected switch machines via Wi-Fi.

- (1) Once you are connected to the module's network, open a browser such as Safari or Chrome and type the following in the URL bar followed by the Enter or Go key: 192.168.7.1  
This is the IP Address of the WFS-43 web pages when you are connected to its wftrex\_WFS43\_1\_XXXXXXXX\_7 network.
- (2) You will see the Main Menu page as in Figure 8

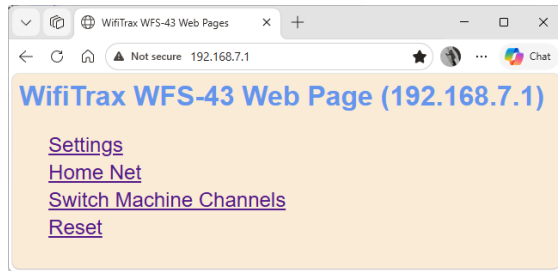

Figure 8. The Main Menu of the WFS-43

(3) To test the switch machine channels, click or tap the Switch Machine Channels option. You will see the screen below. The names of each channel default to the last three digits of the serial number plus the channel number as shown in Figure 9. The DCC Addresses are important once you connect a DCC input or use a WFD-60 as they are used for identification. DCC Addresses in WFS-series modules should be unique across your layout.

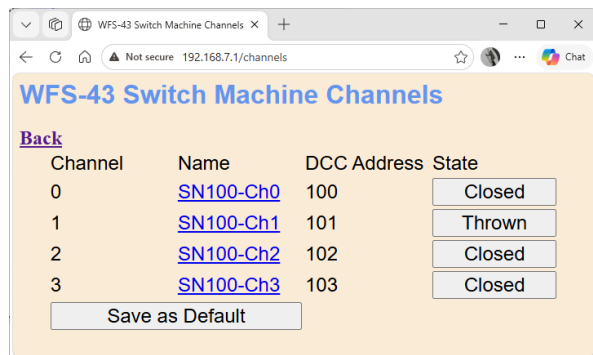

Figure 9. Control of Turnouts using WFS-43 Web Pages before WFS-43 joins home net

Make sure that tapping on the buttons in the State column changes the physical turnout positions from closed to thrown and back.

The Save as Default button will save the current switch settings as the power-on default.

You can also click on each entry in this list to edit the names, DCC addresses and reversed state. DCC addresses are relevant if you connect a DCC Command Station/Booster to the WFD-60 WiThrottle/DCC gateway.

## Integrating the WFS-43 into your System

Once you have completed basic testing you are ready to integrate the WFS-43 into your railroad control system.

### Options for Turnout Control

If you have more than one WFS-43, to allow many turnouts on your layout to be controlled, it will be inconvenient to use each one's individual web pages to control all the turnouts like Figure 7. You need a centralized master. The Wifitrax WFD-60 provides this capability.

The diagrams in Figure 6 and Figure 10 show the options for integrating several WFS-43 Switch Machine Controllers with a Wifitrax WFD-60 WiThrottle and DCC Gateway. The WFD-60 can scan your layout to discover Switch Machine and other controllers and control them all from one central location or indeed several locations. You can also turn off scanning and enter or edit them manually.

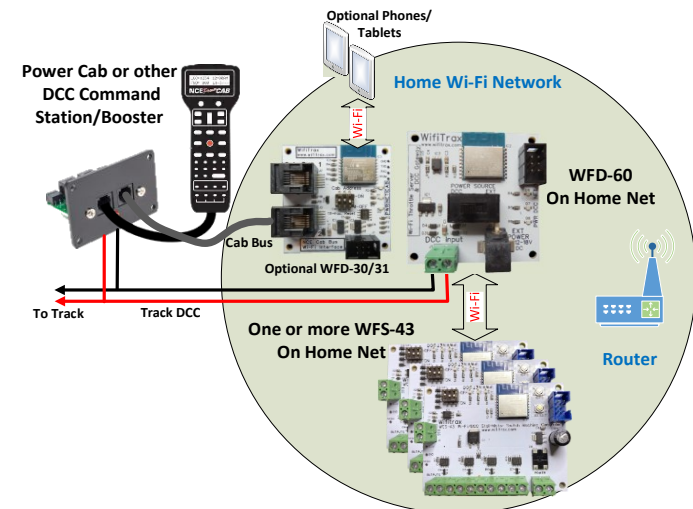

Figure 10. Controlling Points with DCC by Connecting a Command Station to the WFD-60

For this to work, all the WFS-43 (or other WFS controllers) and the WFD-60 need to be placed on your home network so that they can all communicate via a single router.